

# Logic level TOPFET

PIP3105-P

## DESCRIPTION

Monolithic temperature and overload protected logic level power MOSFET in **TOPFET2** technology assembled in a 3 pin plastic package.

## APPLICATIONS

General purpose switch for driving

- lamps
- motors
- solenoids
- heaters

## FEATURES

- TrenchMOS output stage
- Current limiting
- Overload protection
- Overtemperature protection
- Protection latched reset by input
- 5 V logic compatible input level
- Control of output stage and supply of overload protection circuits derived from input
- Low operating input current permits direct drive by micro-controller
- ESD protection on all pins
- Overvoltage clamping for turn off of inductive loads

## QUICK REFERENCE DATA

SYMBOL	PARAMETER	MAX.	UNIT
$V_{DS}$	Continuous drain source voltage	50	V
$I_D$	Continuous drain current	16	A
$P_D$	Total power dissipation	65	W
$T_j$	Continuous junction temperature	150	°C
$R_{DS(ON)}$	Drain-source on-state resistance	50	mΩ
$I_{ISL}$	Input supply current $V_{IS} = 5\text{ V}$	650	μA

## FUNCTIONAL BLOCK DIAGRAM

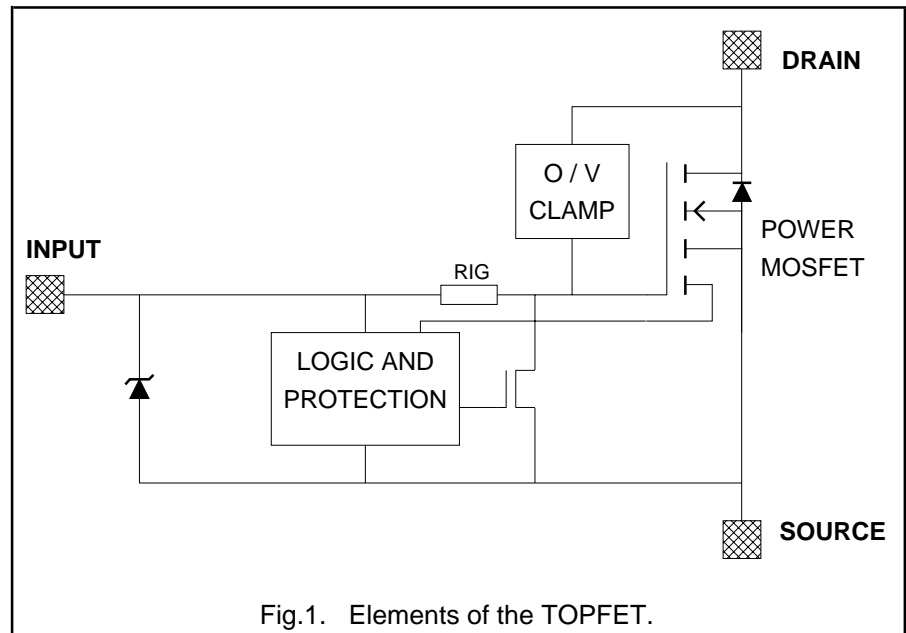

## PINNING - SOT78B

PIN	DESCRIPTION
1	input
2	drain
3	source
tab	drain

## PIN CONFIGURATION

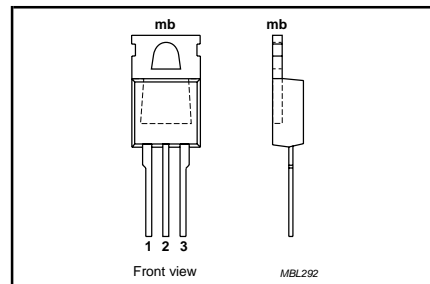

## SYMBOL

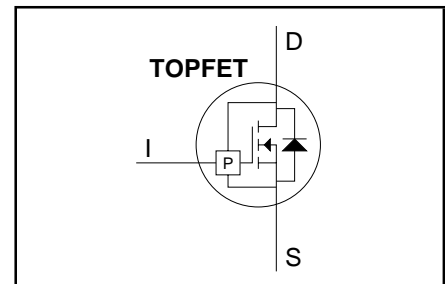

## Logic level TOPFET

PIP3105-P

**LIMITING VALUES**

Limiting values in accordance with the Absolute Maximum Rating System (IEC 134)

SYMBOL	PARAMETER	CONDITIONS	MIN.	MAX.	UNIT
$V_{DS}$	Continuous drain source voltage <sup>1</sup>	-	-	50	V
$I_D$	Continuous drain current	$V_{IS} = 5\text{ V}; T_{mb} = 25\text{ °C}$	-	self - limited	A
$I_D$	Continuous drain current	$V_{IS} = 5\text{ V}; T_{mb} \leq 125\text{ °C}$	-	16	A
$I_I$	Continuous input current	-	-5	5	mA
$I_{IRM}$	Non-repetitive peak input current	$t_p \leq 1\text{ ms}$	-10	10	mA
$P_D$	Total power dissipation	$T_{mb} \leq 25\text{ °C}$	-	65	W
$T_{stg}$	Storage temperature	-	-55	175	°C
$T_j$	Continuous junction temperature <sup>2</sup>	normal operation	-	150	°C
$T_{sold}$	Lead temperature	during soldering	-	260	°C

**ESD LIMITING VALUE**

SYMBOL	PARAMETER	CONDITIONS	MIN.	MAX.	UNIT
$V_C$	Electrostatic discharge capacitor voltage	Human body model; $C = 250\text{ pF}; R = 1.5\text{ k}\Omega$	-	2	kV

**OVERVOLTAGE CLAMPING LIMITING VALUES**

At a drain source voltage above 50 V the power MOSFET is actively turned on to clamp overvoltage transients.

SYMBOL	PARAMETER	CONDITIONS	MIN.	MAX.	UNIT
$E_{DSM}$	<b>Inductive load turn-off</b> Non-repetitive clamping energy	$I_{DM} = 16\text{ A}; V_{DD} \leq 20\text{ V}$ $T_{mb} \leq 25\text{ °C}$	-	200	mJ
$E_{DRM}$	Repetitive clamping energy	$T_{mb} \leq 95\text{ °C}; f = 250\text{ Hz}$	-	32	mJ

**OVERLOAD PROTECTION LIMITING VALUE**

With an adequate protection supply provided via the input pin, TOPFET can protect itself from two types of overload - overtemperature and short circuit load.

SYMBOL	PARAMETER	REQUIRED CONDITION	MIN.	MAX.	UNIT
$V_{DS}$	Drain source voltage <sup>3</sup>	$4\text{ V} \leq V_{IS} \leq 5.5\text{ V}$	0	35	V

**THERMAL CHARACTERISTIC**

SYMBOL	PARAMETER	CONDITIONS	MIN.	TYP.	MAX.	UNIT
$R_{th\ j-mb}$	<b>Thermal resistance</b> Junction to mounting base	-	-	1.75	1.92	K/W

<sup>1</sup> Prior to the onset of overvoltage clamping. For voltages above this value, safe operation is limited by the overvoltage clamping energy.

<sup>2</sup> A higher  $T_j$  is allowed as an overload condition but at the threshold  $T_{j(TO)}$  the over temperature trip operates to protect the switch.

<sup>3</sup> All control logic and protection functions are disabled during conduction of the source drain diode.

## Logic level TOPFET

PIP3105-P

**OUTPUT CHARACTERISTICS**Limits are for  $-40^{\circ}\text{C} \leq T_{\text{mb}} \leq 150^{\circ}\text{C}$ ; typicals are for  $T_{\text{mb}} = 25^{\circ}\text{C}$  unless otherwise specified

SYMBOL	PARAMETER	CONDITIONS	MIN.	TYP.	MAX.	UNIT
$V_{(\text{CL})\text{DSS}}$	<b>Off-state</b> Drain-source clamping voltage	$V_{\text{IS}} = 0 \text{ V}$	50	-	-	V
		$I_{\text{D}} = 10 \text{ mA}$ $I_{\text{DM}} = 2 \text{ A}; t_{\text{p}} \leq 300 \mu\text{s}; \delta \leq 0.01$	50	60	70	V
$I_{\text{DSS}}$	Drain source leakage current	$V_{\text{DS}} = 40 \text{ V}$	-	-	100	$\mu\text{A}$
		$T_{\text{mb}} = 25^{\circ}\text{C}$	-	0.1	10	$\mu\text{A}$
$R_{\text{DS(ON)}}$	<b>On-state</b> Drain-source resistance	$I_{\text{DM}} = 6 \text{ A}; t_{\text{p}} \leq 300 \mu\text{s}; \delta \leq 0.01$	-	-	95	$\text{m}\Omega$
		$V_{\text{IS}} \geq 4.4 \text{ V}$	-	36	50	$\text{m}\Omega$
		$T_{\text{mb}} = 25^{\circ}\text{C}$	-	-	100	$\text{m}\Omega$
		$V_{\text{IS}} \geq 4 \text{ V}$	-	39	55	$\text{m}\Omega$

**OVERLOAD CHARACTERISTICS** $-40^{\circ}\text{C} \leq T_{\text{mb}} \leq 150^{\circ}\text{C}$  unless otherwise specified.

SYMBOL	PARAMETER	CONDITIONS	MIN.	TYP.	MAX.	UNIT
$I_{\text{D}}$	<b>Short circuit load</b> Drain current limiting	$V_{\text{DS}} = 13 \text{ V}$	16	24	32	A
		$V_{\text{IS}} = 5 \text{ V};$ $4.4 \text{ V} \leq V_{\text{IS}} \leq 5.5 \text{ V}$	12	-	36	A
		$4 \text{ V} \leq V_{\text{IS}} \leq 5.5 \text{ V}$	8	-	36	A
$P_{\text{D(TO)}}$ $T_{\text{DSC}}$	<b>Overload protection</b> Overload power threshold Characteristic time	$V_{\text{IS}} = 5 \text{ V}; T_{\text{mb}} = 25^{\circ}\text{C}$	40	120	160	W
		device trips if $P_{\text{D}} > P_{\text{D(TO)}}$ which determines trip time <sup>1</sup>	200	350	600	$\mu\text{s}$
$T_{\text{j(TO)}}$	<b>Overtemperature protection</b> Threshold junction temperature <sup>2</sup>		150	170	-	$^{\circ}\text{C}$

<sup>1</sup> Trip time  $t_{\text{dsc}}$  varies with overload dissipation  $P_{\text{D}}$  according to the formula  $t_{\text{dsc}} \approx T_{\text{DSC}} / \ln[ P_{\text{D}} / P_{\text{D(TO)}} ]$ .

<sup>2</sup> This is independent of the  $dV/dt$  of input voltage  $V_{\text{IS}}$ .

## Logic level TOPFET

PIP3105-P

**INPUT CHARACTERISTICS**

The supply for the logic and overload protection is taken from the input.

Limits are for  $-40^{\circ}\text{C} \leq T_{\text{mb}} \leq 150^{\circ}\text{C}$ ; typicals are for  $T_{\text{mb}} = 25^{\circ}\text{C}$  unless otherwise specified

SYMBOL	PARAMETER	CONDITIONS	MIN.	TYP.	MAX.	UNIT
$V_{\text{IS(TO)}}$	Input threshold voltage	$V_{\text{DS}} = 5 \text{ V}$ ; $I_{\text{D}} = 1 \text{ mA}$ $T_{\text{mb}} = 25^{\circ}\text{C}$	0.6	-	2.4	V
			1.1	1.6	2.1	V
$I_{\text{IS}}$	Input supply current	normal operation; $V_{\text{IS}} = 5 \text{ V}$ $V_{\text{IS}} = 4 \text{ V}$	100	220	400	$\mu\text{A}$
			80	195	330	$\mu\text{A}$
$I_{\text{ISL}}$	Input supply current	protection latched; $V_{\text{IS}} = 5 \text{ V}$ $V_{\text{IS}} = 3 \text{ V}$	200	400	650	$\mu\text{A}$
			130	250	430	$\mu\text{A}$
$V_{\text{ISR}}$	Protection reset voltage <sup>1</sup>	reset time $t_{\text{r}} \geq 100 \mu\text{s}$	1.5	2	2.9	V
$t_{\text{lr}}$	Latch reset time	$V_{\text{IS1}} = 5 \text{ V}$ , $V_{\text{IS2}} < 1 \text{ V}$	10	40	100	$\mu\text{s}$
$V_{\text{(CL)IS}}$	Input clamping voltage	$I_{\text{l}} = 1.5 \text{ mA}$	5.5	-	8.5	V
$R_{\text{IG}}$	Input series resistance <sup>2</sup> to gate of power MOSFET	$T_{\text{mb}} = 25^{\circ}\text{C}$	-	33	-	k $\Omega$

**SWITCHING CHARACTERISTICS**

$T_{\text{mb}} = 25^{\circ}\text{C}$ ;  $V_{\text{DD}} = 13 \text{ V}$ ; resistive load  $R_{\text{L}} = 4 \Omega$ . Refer to waveform figure and test circuit.

SYMBOL	PARAMETER	CONDITIONS	MIN.	TYP.	MAX.	UNIT
$t_{\text{don}}$	Turn-on delay time	$V_{\text{IS}} = 5 \text{ V}$	-	15	30	$\mu\text{s}$
$t_{\text{r}}$	Rise time		-	30	60	$\mu\text{s}$
$t_{\text{doff}}$	Turn-off delay time	$V_{\text{IS}} = 0 \text{ V}$	-	70	140	$\mu\text{s}$
$t_{\text{f}}$	Fall time		-	35	70	$\mu\text{s}$

<sup>1</sup> The input voltage below which the overload protection circuits will be reset.

<sup>2</sup> Not directly measurable from device terminals.

**MECHANICAL DATA**

Plastic single-ended package; heatsink mounted; 1 mounting hole; 3-leads

SOT78B

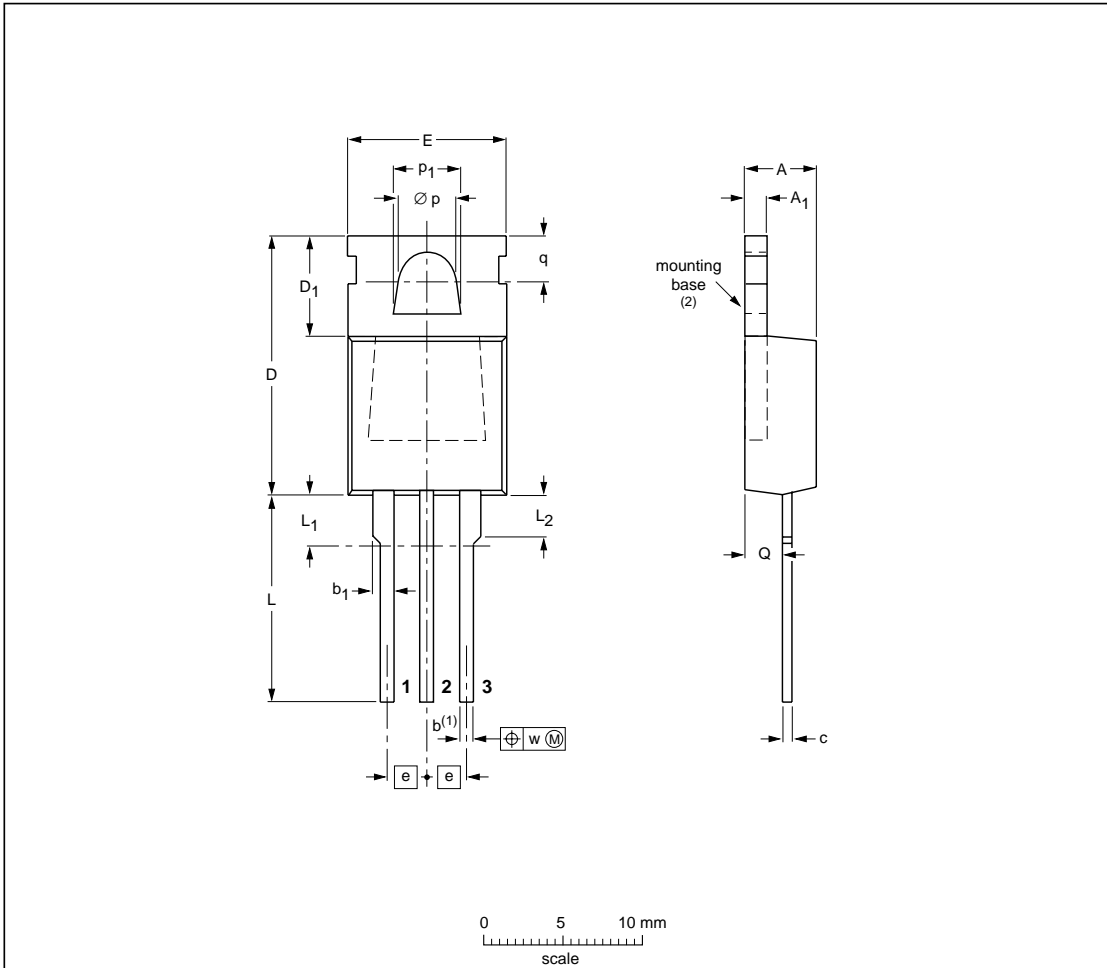

**DIMENSIONS (mm are the original dimensions)**

UNIT	A	A <sub>1</sub>	b <sup>(1)</sup>	b <sub>1</sub>	c	D	D <sub>1</sub>	E	e	L	L <sub>1</sub>	L <sub>2</sub> max.	Ø p	p <sub>1</sub>	q	Q	w
mm	4.5 4.1	1.39 1.27	0.85 0.60	1.3 1.0	0.7 0.4	15.8 15.2	6.4 5.9	10.3 9.7	2.54	15.0 13.5	3.30 2.79	3.0	3.8 3.6	4.3 4.1	3.0 2.7	2.6 2.2	0.4

**Notes**

1. The positional accuracy of the terminals is controlled within zone L<sub>1</sub> max.
2. Mounting base configuration is not defined within the dimensions E and D

OUTLINE VERSION	REFERENCES			EUROPEAN PROJECTION	ISSUE DATE
	IEC	JEDEC	EIAJ		
SOT78B					01-02-22

Fig.2. SOT78B (TO220AB) package<sup>1</sup>, pin 2 connected to mounting base.

<sup>1</sup> Refer to mounting instructions for SOT78 (TO220) envelopes. Epoxy meets UL94 V0 at 1/8". Net mass: 2 g

## Logic level TOPFET

PIP3105-P

**DEFINITIONS**

<b>DATA SHEET STATUS</b>		
<b>DATA SHEET STATUS<sup>1</sup></b>	<b>PRODUCT STATUS<sup>2</sup></b>	<b>DEFINITIONS</b>
Objective data	Development	This data sheet contains data from the objective specification for product development. Philips Semiconductors reserves the right to change the specification in any manner without notice
Preliminary data	Qualification	This data sheet contains data from the preliminary specification. Supplementary data will be published at a later date. Philips Semiconductors reserves the right to change the specification without notice, in order to improve the design and supply the best possible product
Product data	Production	This data sheet contains data from the product specification. Philips Semiconductors reserves the right to make changes at any time in order to improve the design, manufacturing and supply. Changes will be communicated according to the Customer Product/Process Change Notification (CPCN) procedure SNW-SQ-650A
<b>Limiting values</b>		
Limiting values are given in accordance with the Absolute Maximum Rating System (IEC 134). Stress above one or more of the limiting values may cause permanent damage to the device. These are stress ratings only and operation of the device at these or at any other conditions above those given in the Characteristics sections of this specification is not implied. Exposure to limiting values for extended periods may affect device reliability.		
<b>Application information</b>		
Where application information is given, it is advisory and does not form part of the specification.		
© Philips Electronics N.V. 2001		
All rights are reserved. Reproduction in whole or in part is prohibited without the prior written consent of the copyright owner.		
The information presented in this document does not form part of any quotation or contract, it is believed to be accurate and reliable and may be changed without notice. No liability will be accepted by the publisher for any consequence of its use. Publication thereof does not convey nor imply any license under patent or other industrial or intellectual property rights.		

**LIFE SUPPORT APPLICATIONS**

These products are not designed for use in life support appliances, devices or systems where malfunction of these products can be reasonably expected to result in personal injury. Philips customers using or selling these products for use in such applications do so at their own risk and agree to fully indemnify Philips for any damages resulting from such improper use or sale.

<sup>1</sup> Please consult the most recently issued datasheet before initiating or completing a design.

<sup>2</sup> The product status of the device(s) described in this datasheet may have changed since this datasheet was published. The latest information is available on the Internet at URL <http://www.semiconductors.philips.com>.